

Description

RKBI is an insulated centrifugal duct fan with connections for rectangular ducts. The fan have a rigid housing of galvanised steel and are compact with high capacity. With the 50 mm high quality insulation it operates quiet and the surface of the insulation is easy to clean. RKBI is available in 16 capacities. The backward curved impeller gives a better efficiency over a very big working area than the forward curved impeller. The fan is designed to cope with high pressures i.e. long ducts with a minimum of noise. The motor is speed-controllable from 0-100% and maintenance-free, why the only service required is cleaning the impeller. Motor with impeller can be swung out for inspection and cleaning (swing-out). The RKBI fan is supplied fully-wired and ready to fit in a sealed installation unit. It is moisture-proof and approved for use in warm or cold environments. All fans are fitted with a built-in thermal protector.



Technical data

Parameter	Value	Unit
Voltage	400	V
Phase	3	~
Frequency	50	Hz
Power	0.78	kW
Current	1.55	A
R.p.m.	23	r/s
Max. temperature of transported air	60	°C
Max. temperature of transported air when speed-controlled	55	°C
Sound pressure level at 3 m	51	dB(A)
Length	817	mm
Width	807	mm
Height	549	mm
Weight	62.5	kg
Enclosure class, motor	44	IP
Insulation class, motor	F	
Duct connection	700x400 mm	

Diagrams

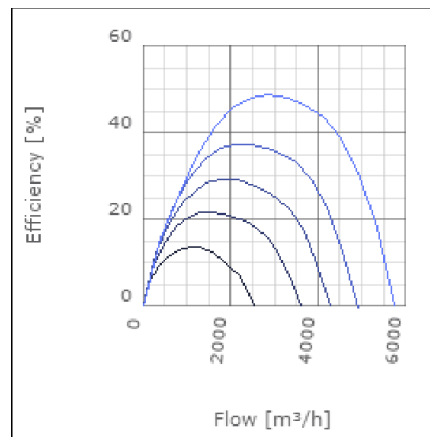
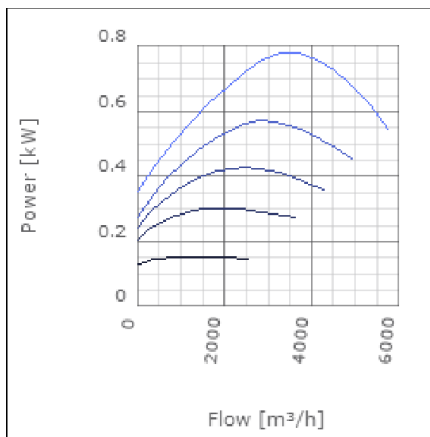
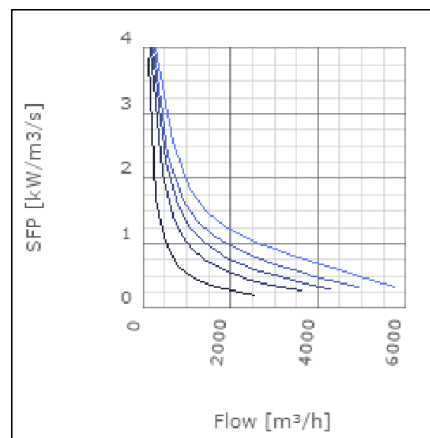
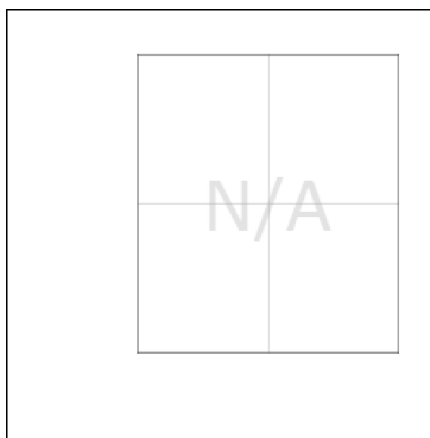
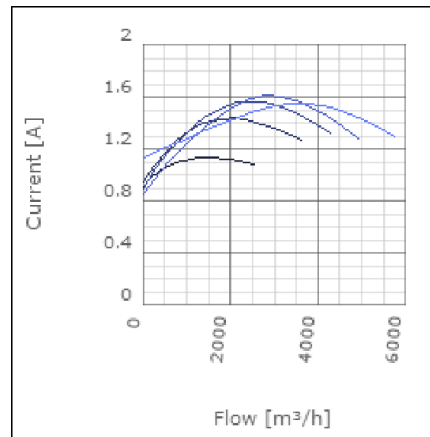
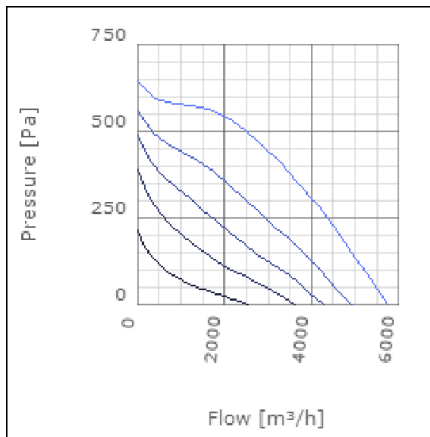

Sound

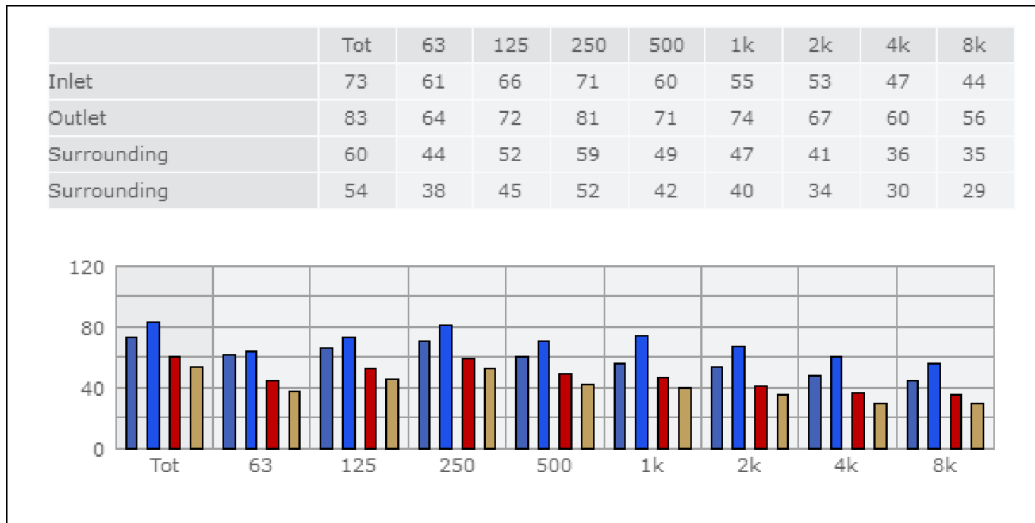

Parameter

Distance: 3.000
 Propagation type: Hemi-spherical
 Equivalent absorption area: 20.00

Checked point

Flow 3140.288m³/h
 Static pressure 429Pa

Working point

Flow 3141.437m³/h
 Static Pressure 430Pa
 Power 0.77kW
 Speed 0r/s
 Current 1.55A
 Voltage 400V
 Efficiency 48.483%
 SFP 0kW/m³/s

Dimensions

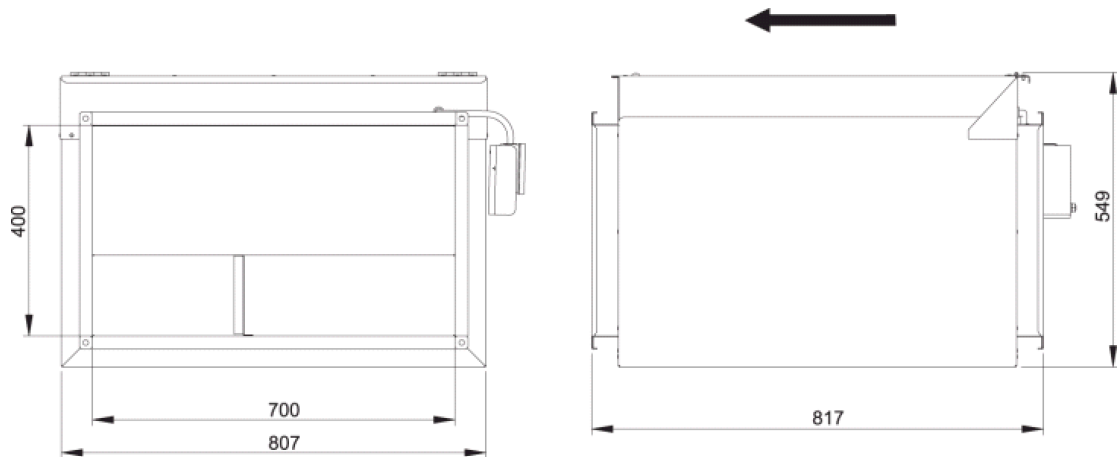

Wiring diagram

4040004

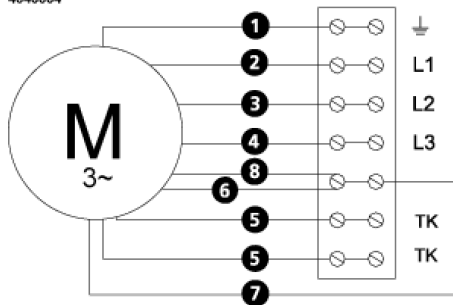

- (M) = Fan Motor
- (M1) = Fan Motor
- (M2) = Fan Motor
- (M3) = Rotor Motor
- 1 = Yellow/Green
- 2 = Black
- 3 = Blue
- 4 = Brown
- 5 = White (TW)
- 6 = Orange
- 7 = Grey
- 8 = Red
- 9 = Green
- 10 = Violet

Accessories

VRDT 2
VRTT 2

Electrical accessories

FLR 700x400
DS 700x400
LDR 700x400